

FICHE D'HOMOLOGATION / HOMOLOGATION FORM

017-BS-91



COMMISSION
INTERNATIONALE
DE KARTING - FIA



CARROSSERIE LATERALE / SIDE BODYWORK

Constructeur / <i>Manufacturer</i>	Parolin Racing Kart srl
Marque / <i>Make</i>	Eurostar
Modèle / <i>Model</i>	Dynamica Mini
Catégorie / <i>Categorie</i>	Group 3
Durée de l'homologation / <i>Validity of the Homologation</i>	4 ans / 4 years
Nombre de pages / <i>Number of pages</i>	4
La présente Fiche d'Homologation reproduit descriptions, illustrations et dimensions du carrosserie laterale au moment de l'homologation CIK-FIA.	<i>This Homologation Form reproduces descriptions, illustrations and dimensions of the side bodywork at the moment of the CIK-FIA homologation.</i>



Photos vue de côté de carrosserie lateral / *Photo of the side of the bodywork*

Signature et tampon de l'ASN /
Signature and stamp of the ASN



Signature et tampon de la CIK-FIA /
Signature and stamp of the CIK-FIA



Photo vue dessus avec supports / Photo from above with supports



Photo vue de devant avec supports / Photo from the front with supports



A

Cotes / Dimensions

Carrosserie lateral supports / Side bodywork with supports

Dessin technique (Dimensions d'encombrement/Matériaux, diamètre et épaisseur des tubes supports) /
 Technical drawing (Fairing main external dimensions/Material, diameter and wall thickness of supports)

Carrosserie (droite ou gauche seule) masse en gramme /
 Bodywork (RH or LH only) mass in gram

520 gr

± 10 %

Support (droite ou gauche seul) masse en gramme /
 Support (RH or LH only) mass in gram

855 gr

± 5 %

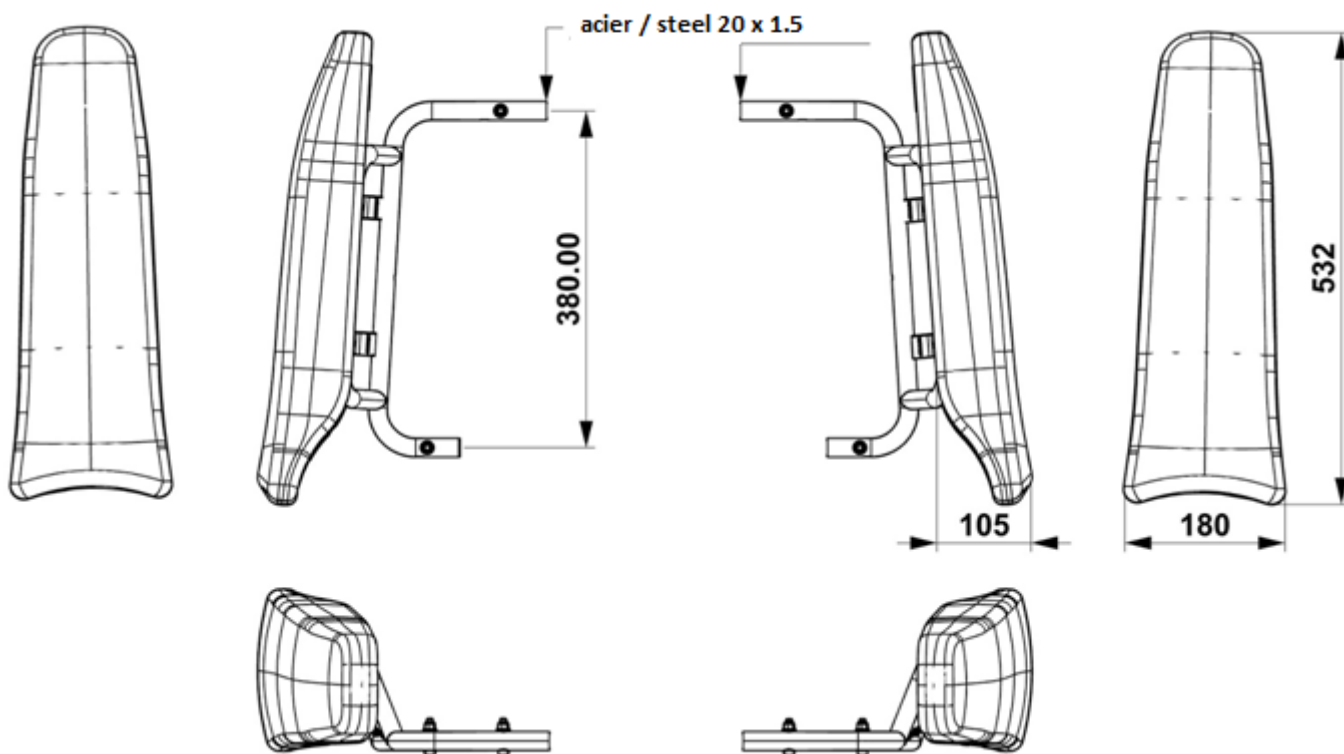

D

**Photo du marquage de numéro d'homologation et CIK-FIA logo/
Photo of marking of homologation number and CIK-FIA logo**

Carrosserie latérale sur les éléments plastiques / *Lateral bodywork plastic part*



Supports / *Supports*



Le marquage et le numéro d'homologation doivent rester clairement visibles en permanence. /
The marking and the homologation number must remain clearly visible permanently.